

BALLUFF

sensors worldwide

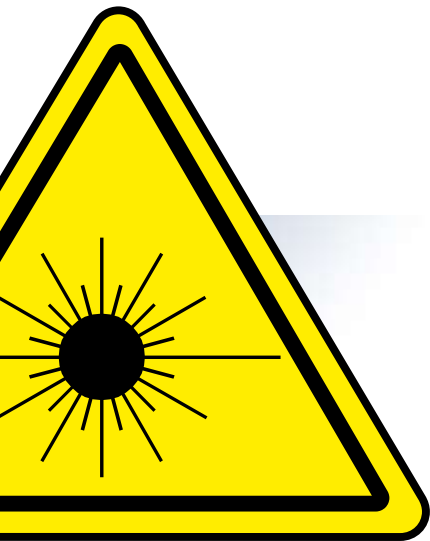

BOD 21M Distance Sensors

Effortless performance – High efficiency

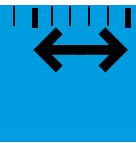

more added value

Linear Position Sensing

Comprehensive systems expertise. Technological variety. Optimal solutions.

Displacement sensing – exactly what you need!

You work efficiently and need optimal solutions? When it comes to linear position sensing Balluff gives you exactly what you need. A variety of operating principles is available: For distances of from 1...48000 mm and resolutions from 1...100 μm . The choice is yours. Simply pick the system that's right for your. And use Balluff's mature linear displacement sensing technology to increase your added value.

Balluff displacement sensing technology: Rugged and designed for industry, precise and reliable, non-contact and wear-free.

more added value

- Greater flexibility through full range of sensing principles
- More efficiency through optimal solutions
- Increased productivity through well-engineered displacement sensing technology

BML 48 000 mm

BML Magnetic Linear Encoder System – Highly precise with long lengths

BTL/BIW 7 500 mm

BTL Micropulse Transducer/BIW Inductive Linear Position Sensor – Extremely rugged and reliable

BOD 6 000 mm

BOD Photoelectric Distance Sensors – For any material or object color

BIL 160 mm

BIL Magneto-inductive Position Sensors – Compact and absolute

BAW 20 mm

BAW Inductive Distance Sensors – For short strokes

 IO-Link



Photoelectric Distance Sensors

Sense any material or color, intelligent and flexible.

Positioning with precision, ensuring maximum quality and efficiently controlling material flow means distance measurement using Balluff photoelectric distance sensors. The versatile BOD 21M in its compact, rugged metal housing expands your application options in a product family including through-beam sensors, contrast and luminescence sensors.

Wide-ranging functionality, the most modern sensor technology and innovative manufacturing technology leave nothing to be desired: For robotics and automation, assembly and handling as well as packaging technology.

- more added value**
- Variety of functions in a standard housing
 - Rugged metal construction
 - Adaptable installation

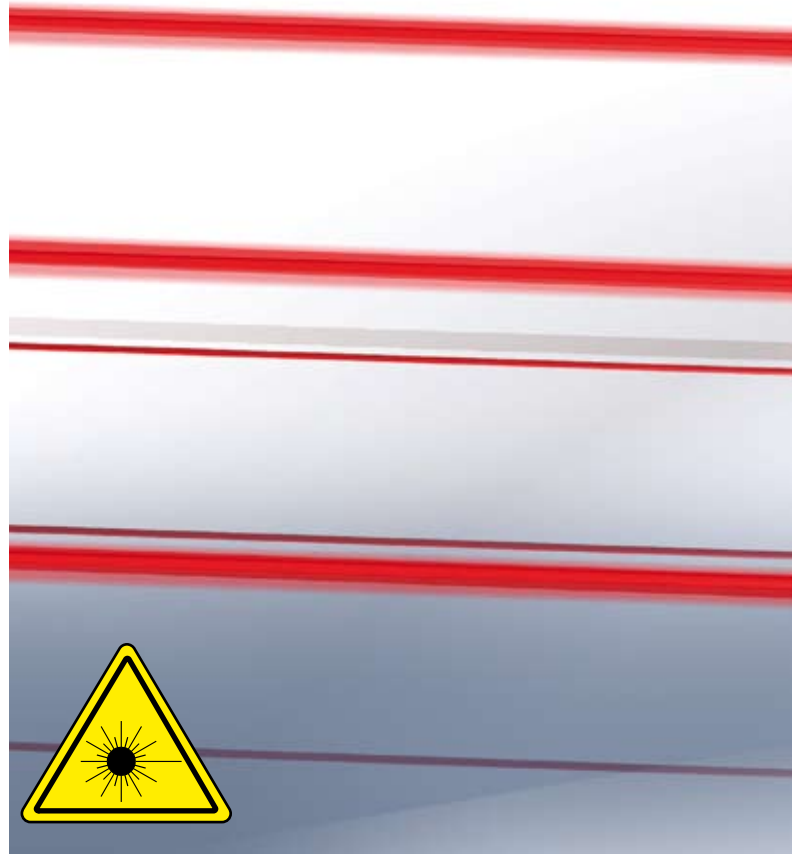

Simply choose from among the variety of applications offered by the BOD 21M thanks to its output signal proportional to object distance. Color and material of the object are effectively ignored.

Rapid startup and ease of operation with a rotary switch for teach-in mean added cost-effectiveness. And installation couldn't be easier. A variety of mounting brackets, dovetail clamps and a comprehensive mounting system means the BOD 21M can be conveniently attached and oriented in any position.

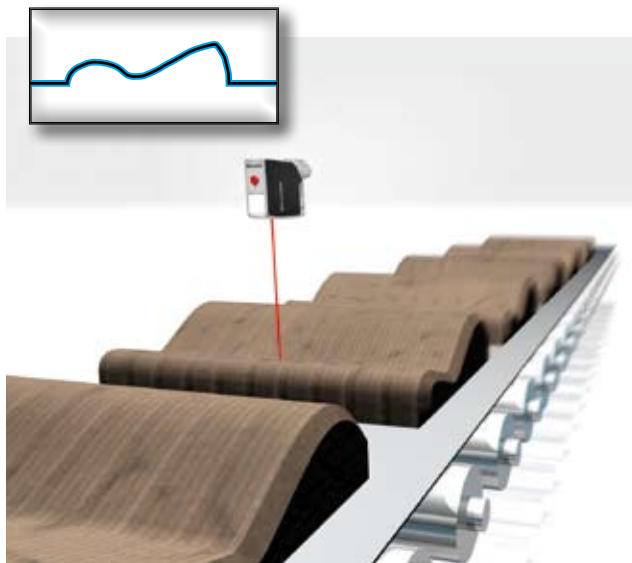

Contour checking

Optical distance sensors continuously detect dimensions or contours on tongue and groove boards. Analog sensing detects individual defects and gradual deviations directly for permanent monitoring of the production process.

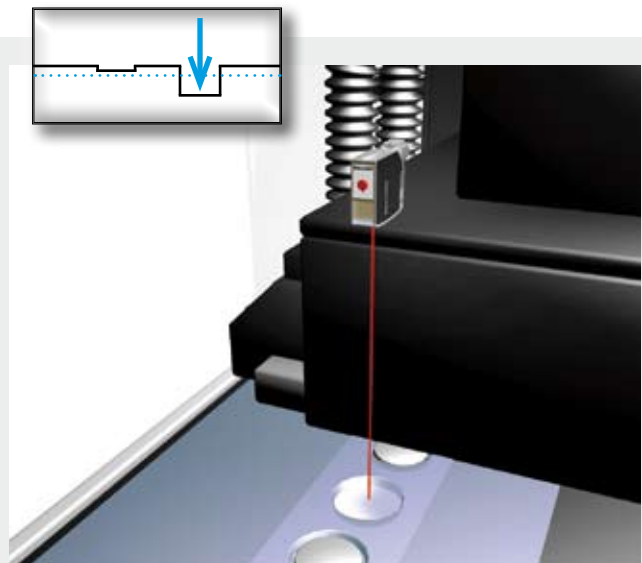

Blister packaging

Optical distance sensors monitor the packaging process, optimize product filling and increase system productivity. Before foil packaging is closed up, a BOD 21M checks the individual compartments and detects missing or extra items.

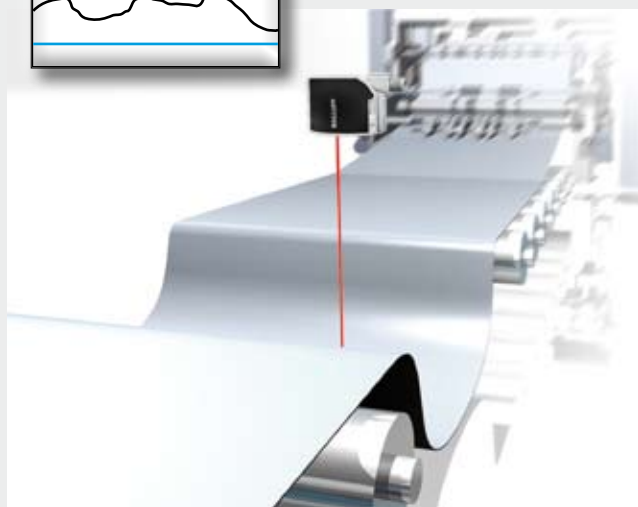
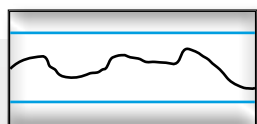

Sag monitoring

Precise processing of films or sheet material requires that it be uniformly conveyed. Tension-free material transport succeeds using the BOD 21M, which dynamically detects the height of the sag section.

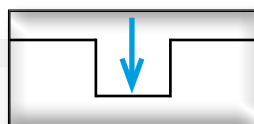

Adaptive feed

Multiple optical distance sensors measure components, assembled units and packages on a conveying line. BOD 21M sensors evaluate the outer dimension and contour so that these various parts can be transported to the next appropriate process steps. The rugged metal housing guarantees long service life of the installation.

Photoelectric Distance Sensors

Series BOD 21M

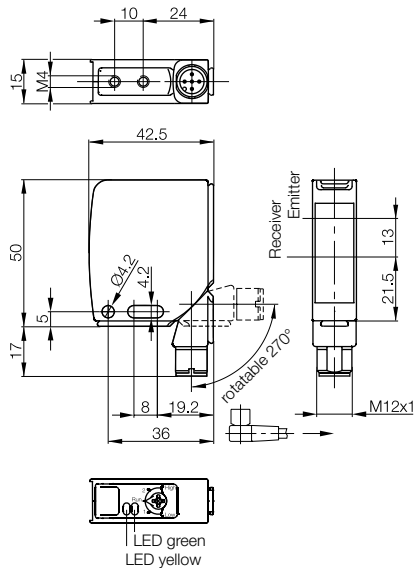

The BOD 21M provides a continuous voltage or current signal proportional to the object distance. The measuring range of 20...500 mm is freely selectable and can be set for your application using the convenient rotary switch.

Two independent switching outputs with push-pull final stage allow you to use the new BOD 21M as either PNP normally open or NPN normally closed. Using the switching points – easy to select using a rotary switch – you can employ background suppression and reliable zone monitoring.

Features

- Measuring range selectable between 20 and 500 mm
- Analog voltage or current signal
- Two digital switching outputs, individually configurable
- Central rotary switch for ease of setting
- Rugged metal housing
- M12 connector, rotatable 270°



The BOD 21M is connected using a 5-pin M12 plug. The connector orientation can be set over a range of 270°, allowing the BOD 21M to be attached in any position.

The measuring range and switching points are easily set using the rotary switch.



Series	
Working range	
Measuring range	
Voltage output	
Current output	
Supply voltage U_B	
Ripple	
No-load supply current I_0 max.	
Analog output	Voltage output Current output
Settings	
Emitter, light type	
Wavelength	
Laser Class	
Light spot diameter	
Temperature drift	
Resolution	
Linearity	
Ready delay	
On-/off-delay	
Switching frequency f	
Power-on indicator	
Output function indicator	
Connection	
Housing material	
Optical surface	
Weight	
Degree of protection per IEC 60529	
Polarity reversal protected	
Short circuit protected	
Permissible ambient light	
Ambient temperature range T_a	

Measured values referenced to Kodak gray card 90 % reflective.

 -- Connector orientation



more added value

- Long measuring range with high resolution
- Highly visible red light facilitates alignment
- Fully adaptable to your application

Photoelectric Distance Sensors Series BOD 21M



BOD 21M	BOD 21M	BOD 21M
25...45 mm	20...200 mm	20...500 mm
20 mm	180 mm	480
BOD 21M-LA01-S92	BOD 21M-LA02-S92	BOD 21M-LA04-S92
BOD 21M-LB01-S92	BOD 21M-LB02-S92	BOD 21M-LB04-S92
18...30 V DC	18...30 V DC	18...30 V DC
≤ 15 %	≤ 15 %	≤ 15 %
≤ 50 mA	≤ 50 mA	≤ 50 mA
1...10 V	1...10 V	1...10 V
4...20 mA	4...20 mA	4...20 mA
Teach-in (rotary switch)	Teach-in (rotary switch)	Teach-in (rotary switch)
Laser, pulsed red light	Laser, pulsed red light	Laser, pulsed red light
630 nm	630 nm	630 nm
2	2	2
Ø1 mm at 45 mm	Ø1 mm at 200 mm	1×6 mm at 500 mm
≤ 0.2 %/°K	≤ 0.2 %/°K	≤ 0.2 %/°K
30 µm	100...200 µm	100...500 µm
~0.5 %	± 1 %	± 1 % (up to 200 mm) ± 3 % (200...500 mm)
≤ 300 ms	≤ 300 ms	≤ 300 ms
≤ 7 ms	≤ 7 ms	≤ 7 ms
≤ 70 Hz	≤ 70 Hz	≤ 70 Hz
LED green	LED green	LED green
LED yellow	LED yellow	LED yellow
M12 connector, 5-pin	M12 connector, 5-pin	M12 connector, 5-pin
Gd-Zn	Gd-Zn	Gd-Zn
Glass	Glass	Glass
80 g	80 g	80 g
IP 67	IP 67	IP 67
yes	yes	yes
yes	yes	yes
5 kLux	5 kLux	5 kLux
-10...+50 °C	-10...+50 °C	-10...+50 °C

Wiring diagrams

BOS 21M-LA...

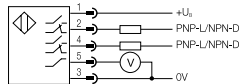

BOS 21M-LB...

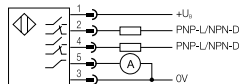

Connector diagram



Laser class

The emitter conforms to Laser Class 2 in accordance with EN 60825-1:2001-11. This means no additional safety measures are necessary.

Install the device so that the laser warning label is easily visible.



Recommended accessories

please order separately



Mounting brackets
BOS 21-HW-1, BOS 21-HW-2

Connector
BKS-S137-17-PU-05

Balluff GmbH
Schurwaldstrasse 9
73765 Neuhausen a.d.F.
Germany
Phone +49 7158 173-0
Fax +49 7158 5010
balluff@balluff.de